

# Conductive Limit Detection

## Double-rod probes 11362, 11362 Z

**High resistant probes,  
for corrosive liquids,  
for use in plastic vessels**



The probe rods and process connections are made from highly corrosion-resistant materials for use with aggressive products.

## Application

### Limit Detection

The probes are for those applications requiring accurate limit detection or overspill protection in plastic vessels or vessels made of non-conducting material.

### Two-point Control

Two-point control can be carried out in vessels with electrically conducting walls.

### Variable Process Connections

- Thread G1 1/2 A (parallel)
- Thread 1 1/2" NPT (tapered)
- Flanges conforming to DIN, from DN 40 to DN 200, PN 16 or PN 40, also available with groove-ring or tongue
- Flanges conforming to ANSI, from 1 1/2" to 4", 150 psi or 300 psi, also available with ring joint (11362 only).

### Function Monitoring

An EW 11 Z electronic insert can be installed for continuous cable monitoring with maximum limit indication when using a Nivotester FTW 470 Z/ 570 Z/ 520 Z (required when using the probe for overspill protection).

### Applications in Ex-Areas

- The 11362 Z version can be used
- For applications in explosion hazardous area, Zone 0,
  - For applications in waste water plants, which are sometimes regarded as Zone 0 (gasoline and oil traps etc.).
  - As overspill protection for flammable and non-flammable water-polluting liquids (VbF, WHG §19).

Endress + Hauser

The Power of Know How



# The Complete Measuring System

In addition to the double-rod probe, the complete measuring system comprises one conductivity limit switch

- Nivotester FTW 470 Z in Racksyst plug-in board format for the standard calibration range 1 k $\Omega$ ...50 k $\Omega$   
or
- Nivotester FTW 570 Z in Racksyst plug-in board format for the extended calibration range 100  $\Omega$ ...50 k $\Omega$  (for conductive deposits on the probe insulation)

or

- Nivotester FTW 520 Z in Minipacrow housing with the calibration range 100  $\Omega$ ...50 k $\Omega$   
or
- Nivotester FTW 420 in Minipac row housing with the calibration range 0...50 k $\Omega$  or 0...1.5 k $\Omega$  (FTW 420 S) for non-certified applications.

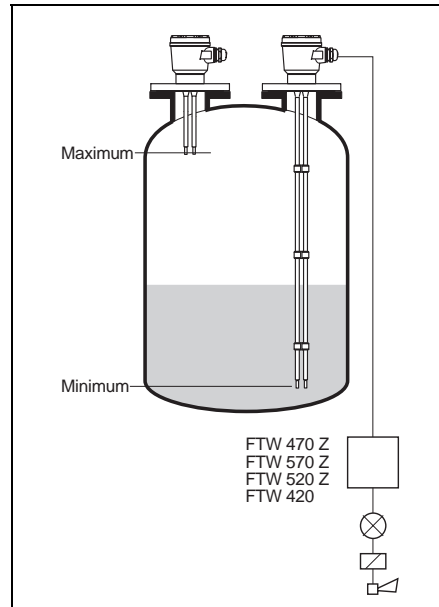

Limit detection  
in a plastic vessel

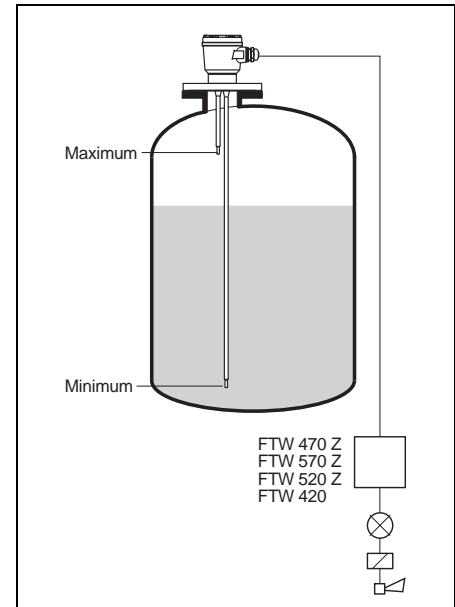

Two-point control  
in a metal vessel

## Installation

- The probes are designed to be installed vertically for most applications.
- Compact probes up to approx. 300 mm in length can be installed at any orientation.
- A support is required for those probes subjected to high lateral loads.
- For liquids tending to deposit a conductive layer on the probe insulation, the final spacer should be moved at least 100 mm away from the end for high contact resistance when the probe is exposed.
- If the probe has to be shortened, then clamp the rods such that the insulation is not damaged and that the feed-throughs in the flange or threaded boss are not subject to mechanical force. Remove the rod insulation at the probe tip by at least a further 20 mm (see Technical Data).

# Electrical Connection

The 11362/11362 Z probe is supplied with either an integrated EW 11 Z electronic insert for cable monitoring or an integrated terminal block.

The use of the probe in explosion hazardous areas is not permitted when it is connected to the Nivotester FTW 420. After connecting, make sure that the cable gland and the probe housing are tight.

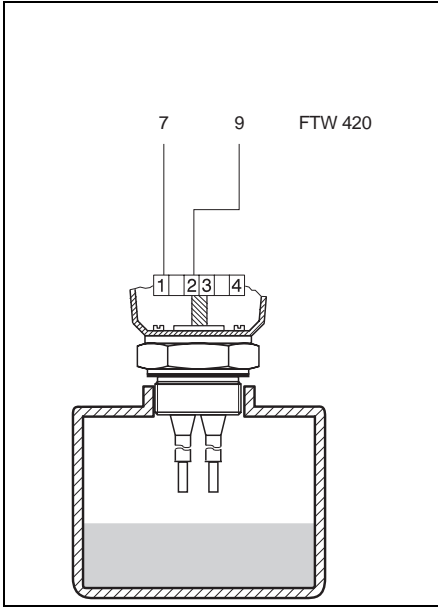

Freely selectable limit detection in a plastic vessel without cable monitoring.

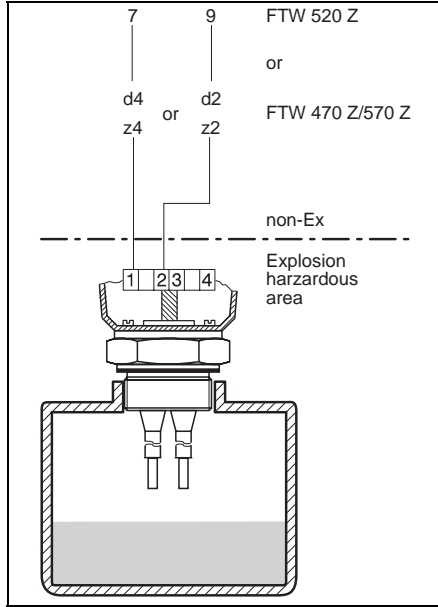

Freely selectable limit detection in a plastic vessel without cable monitoring and also for use in explosion hazardous areas.

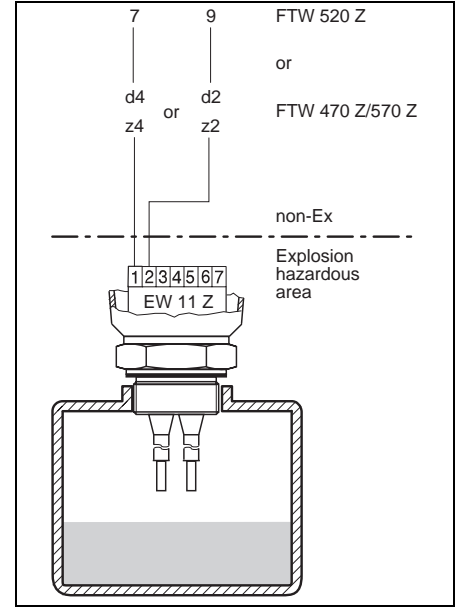

(Maximum) limit detection in a plastic vessel with cable monitoring and also for use in explosion hazardous areas.

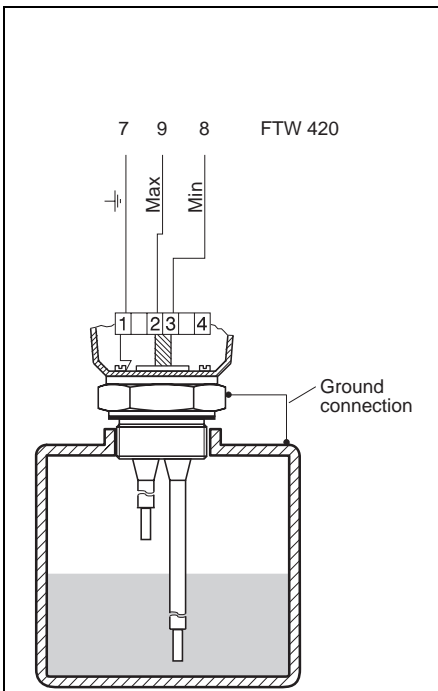

Two-point control in a metal vessel without cable monitoring.

It is important to have a good ground connection between the probe head and the vessel.

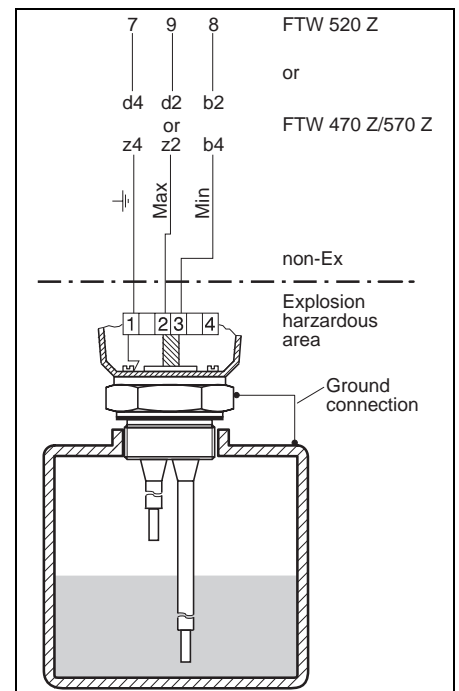

Two-point control in a metal vessel without cable monitoring and also for use in explosion hazardous areas.

It is important to have a good ground connection between the probe head and the vessel.

# Technical Data

The most important data are listed in the ordering diagram.

Further Technical Data:

### Other Materials

Spacer material: PFA  
Seal for version with thread: elastomer/fibre, non-asbestos

### PTFE Insulation Lengths (standard)

Probe length L	Insulation length	
	with EW 11 Z	with terminals
up to 150 mm	L minus 10 mm	L minus 10 mm
150...2000 mm	L minus 20 mm	L minus 20 mm
2000...3000 mm	L minus 30 mm	L minus 30 mm
3000...4000 mm	L minus 30 mm	L minus 70 mm

### Operating Pressures and Temperatures

- Metal process connections  
Operating pressure and temperature see drawing below

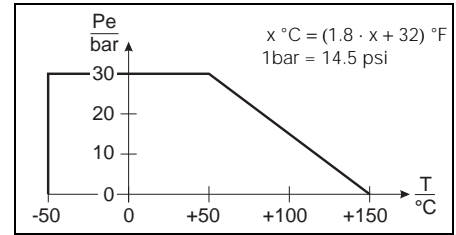

- Plastic process connections  
Operating pressure  $p_e$  -0.2...+0.2 bar  
Temperature -25...+80°C

### Important

The maximum permissible operating temperature is 80°C when using the EW 11 Z electronic insert

### Mechanical Connection

The dimensions of plastic connection flanges in PP or PTFE correspond to DIN flanges for PN 16 or ANSI flanges for 150 psi.

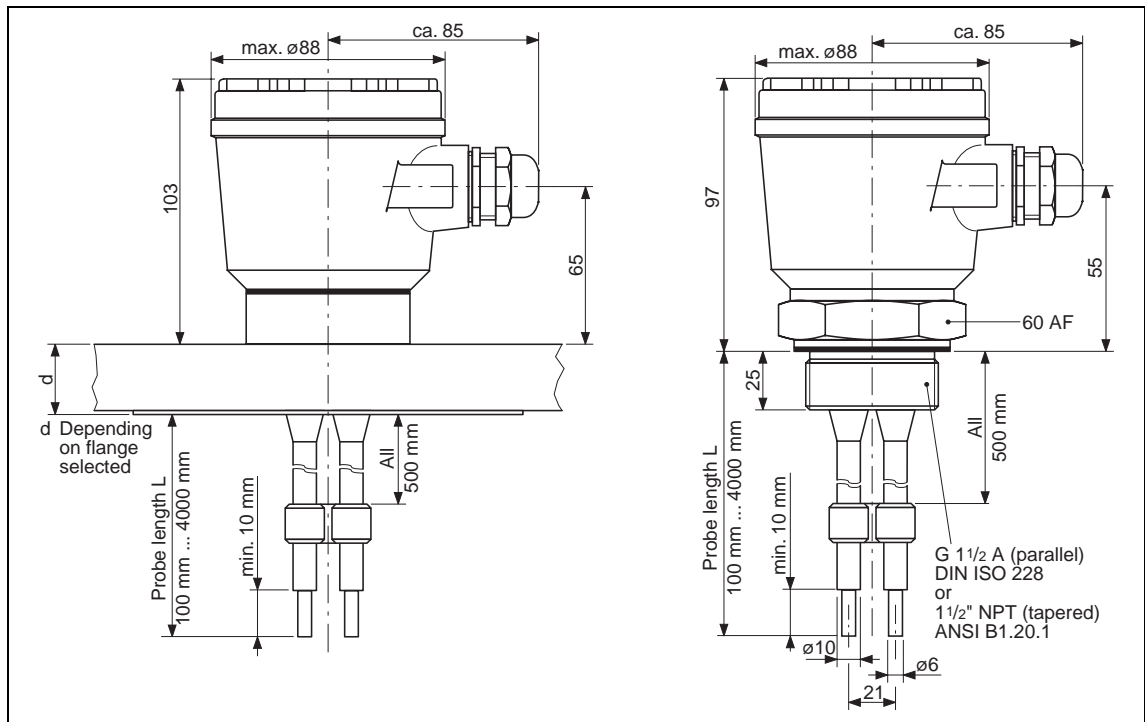

Dimensions in mm of the double-rod probes 11362 and 11362 Z. Height and diameter are similar for all housings.

100 mm = 3.94 in  
1 in = 25.4 mm



## Supplementary Documentation

- Nivotester FTW 470 Z/570 Z  
Conductivity limit switch for liquids.  
Double limit switch in Racksyst  
format, also for two-point control.  
Technical Information TI 039

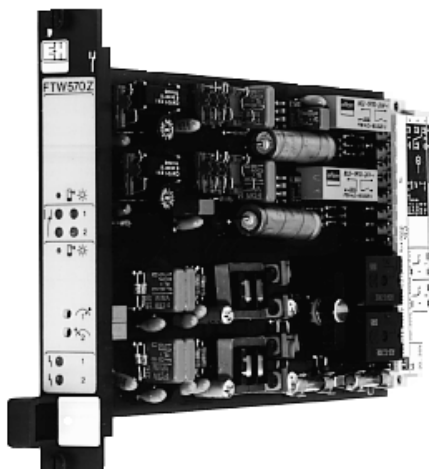

- Nivotester FTW 520 Z  
Conductivity limit switch for liquids  
in Minipac row housing, also for  
two-point control.  
Technical Information TI 079



- Three-rod probe 11363, 11363 Z.  
Technical Information TI 122

- Nivotester FTW 420  
Conductivity limit switch for liquids  
in Minipac row housing, also for  
two-point control. Standard version  
(not certified).  
Technical Information TI 080





---

---

Endress+Hauser  
GmbH+Co.  
Instruments International  
P.O. Box 2222  
D-79574 Weil am Rhein  
Germany

Tel. (07621) 975-02  
Tx 7 73 926  
Fax (07621) 975-3 45  
<http://www.endress.com>  
[info@ii.endress.com](mailto:info@ii.endress.com)

Endress + Hauser  
The Power of Know How

